

# Inductivity and Bridging in Carbocations

CYRIL A. GROB

*Institute of Organic Chemistry, University of Basel, 4056 Basel, Switzerland*

*Received December 2, 1982 (Revised Manuscript Received June 15, 1983)*

The question whether carbocations are bridged first arose in connection with attempts to describe the short-lived intermediates in the solvolysis of bicyclic halides and sulfonates, notably of norbornane derivatives.<sup>1,2</sup> But it is now clear that the question relates to carbocation structure in general.

The advent of new and powerful spectroscopic techniques has extended the field of inquiry to long-lived carbocations that, however, tend to undergo deep-seated rearrangements to more stable structures.<sup>3</sup> Of late, greatly refined and hence more trustworthy theoretical calculations have been brought to bear on the problem.<sup>4</sup>

This Account is concerned with the original question, namely, the structure and reactions of the transient carbocations that are formed in the solvolysis of acyclic and cyclic halides and arenesulfonates. It describes a new approach based on the assumption that through-space induction and bridging are related phenomena.

## Bridging

Concerned mainly with the bonds between adjacent C atoms, organic chemists have tended to neglect interactions between alternate C atoms, i.e., between C-1 and C-3 in the structure 1, which are the next nearest C atoms and maintain a constant distance of ca. 2.5 Å. In fact, electron density maps as well as space-filling molecular models show that the electrons that link a chain of atoms also occupy the space between alternate nuclei. Nevertheless, interaction between the latter does not result in bonding as long as C-1 is tetracoordinate and surrounded by an octet of electrons. This is no longer the case when extrusion of the nucleofuge X leads to a cationic center at C-1 that attracts the surrounding electrons. Spectroscopic evidence shows that the electron deficiency is spread over neighboring atoms.<sup>3</sup>

The crucial question is whether the electrons around C-3, or even more remote C atoms, move directly, i.e., through space, toward C-1 and thereby give rise to a secondary bonding interaction illustrated by the dashed line in cation 2. This so called 1,3-bridging converts

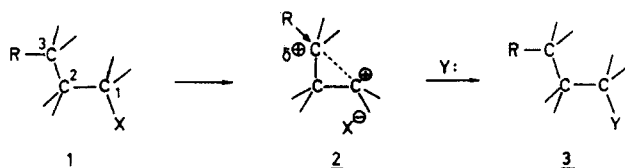

the tetracoordinate C-3 into a pentacoordinate atom and should be accompanied by shortening of the C-1

Cyril A. Grob was born of Swiss parents in London, U.K., in 1917. He obtained a diploma in chemistry and a doctor's degree, both at the Federal Institute of Technology in Zürich, Switzerland. Following postdoctoral research at Basel University and at the University of California, Los Angeles, he became associate professor at Basel University in 1951 and full professor in 1954. Earlier interests were centered on natural products, more recently on heterolytic fragmentation, carbocations, including vinyl and homoallylic cations, and polar substituent effects.

to C-3 distance. Furthermore, bridging should direct the attack of an external nucleophile Y to the unbridged side of cation 2 and therefore lead to a product 3 with the same configuration as 1. Bridging, as described here, results from electrophilic attack of a cationic center on a neighboring tetrahedral C atom or, conversely, as a nucleophilic attack of the latter at the rear of a C-X bond in the manner of a S<sub>N</sub>2 reaction. Therefore, the following conditions should be fulfilled for bridging to occur to an appreciable extent.

(1) Attack by nucleophilic solvents at the rear of C-1 must be strongly hindered in order to prevent competition by a bimolecular (S<sub>N</sub>2) displacement reaction by the solvent, i.e., by a *k<sub>s</sub>* process.<sup>5</sup> This is the case when the nucleofuge X is attached to a tertiary C atom, especially if the latter is situated at the bridgehead of a polycyclic system but also when X is located adjacent to a tertiary C atom, as in neopentyl- and pinacolyl-like structures. As recently pointed out,<sup>6</sup> rearside hindrance also occurs in bi- or tricyclic molecules in which X is next to one or two bridgehead atoms. In all such cases reaction takes place without nucleophilic solvent participation, i.e., by a *k<sub>c</sub>* or *k<sub>Δ</sub>* process.<sup>5</sup> Since the positive charge generated in the ionization step cannot be directly transferred to the solvent, it seeks to undergo stabilization by other means, such as induction, hyperconjugation, rearrangement, fragmentation, or hydrogen shifts. If these internal models of charge dispersal are also lacking, very low reactivity will result.

(2) Substituents R on the bridging atom C-3 in 2 should act as electron donors relative to the incipient cationic center at C-1, for only then can C-3 facilitate ionization by dispersing the positive charge generated at C-1 in the transition-state 4.

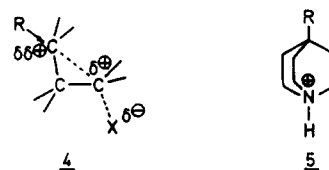

(3) Both C atoms involved in bridging, i.e., C-1 and C-3, should be able to adopt, at least approximately, the trigonal-bipyramidal configuration favored by pentacoordinate atoms.<sup>7</sup> Deviations from this preferred arrangement will lead to a strained transition state and hence reduce bridging and rate.

(1) Nevell, T. P.; de Salas, E.; Wilson, C. L. *J. Chem. Soc.* 1939, 1188.

(2) Winstein, S.; Trifan, D. S. *J. Am. Chem. Soc.* 1949, 71, 2953; 1952, 74, 1147, 1154. Winstein, S. *Ibid.* 1965, 87, 381.

(3) Olah, G. A. *Chem. Scr.* 1981, 18, 97.

(4) Goddard, J. D.; Osamura, Y.; Schaefer, H. F., III *J. Am. Chem. Soc.* 1982, 104, 3258.

(5) Winstein, S.; Alfred, E.; Glick, R. *Tetrahedron* 1958, 3, 1. Schadt, F. L.; Bentley, T. W.; Schleyer, P. v. R. *J. Am. Chem. Soc.* 1976, 98, 7667. There is no sharp distinction between *k<sub>s</sub>*, *k<sub>Δ</sub>*, and *k<sub>c</sub>* processes; in all probability they merge.

(6) Grob, C. A.; Lutz, E. *Helv. Chim. Acta* 1981, 64, 153.

(7) Muetterties, E. L.; Schunn, R. A. *Q. Rev.* 1966, 20, 245.

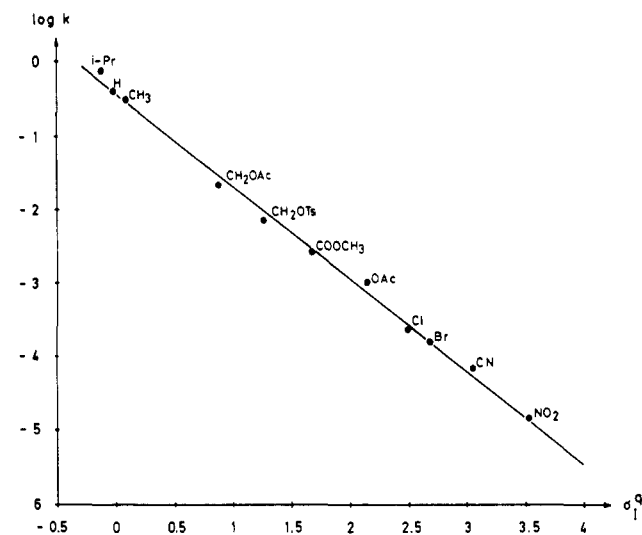

Figure 1. Plot of  $\log k$  for 3-substituted-1-adamantyl tosylates 18 vs. inductive substituent constants  $\sigma_I^q$ .

As defined here, bridging is strongly controlled by stereoelectronic factors.

### Detection of Bridging

Earlier studies in this laboratory have shown that the solvolysis rates of saturated cyclic and acyclic halides and sulfonates are determined by the inductive effect of neighboring substituents, provided these do not induce fragmentation or participate in cyclization.<sup>8</sup> This conclusion follows from the linear correlation between the logarithms of the first-order rate constants ( $\log k$ ) and the respective inductive substituent constants  $\sigma_I^q$ . Since the latter were derived from the  $pK_a$  values of 4-substituted quinclidinium perchlorates 5, in which steric, conjugative, and hyperconjugative effects are negligible or absent,<sup>9</sup> a linear correlation indicates that ionization rates are controlled by the inductive effect of the substituents alone and that the Hammett-Taft equation  $\log(k/k_0) = \rho\sigma_I^q$  applies ( $k$  and  $k_0$  denote the rate constants for the substituted and unsubstituted substrate, respectively).

Figure 1 illustrates the linear relationship observed for the reaction of 3-substituted-1-adamantyl tosylates (tosylates) 18 in 80 vol % ethanol.<sup>8e</sup> This solvent was chosen because it offers the combination of ionizing power and nucleophilicity required for ready ionization of tosylates and capture of the intermediate carbocations. The reaction constant  $\rho$ , derived from the slope of the regression line, is a measure of the sensitivity of the reaction rate to the  $I$  effect of the substituents, i.e., the *inductivity* of the system. The  $\rho$  values for the solvolysis of various acyclic and cyclic compounds have been determined by this method and shown to vary over a wide range, although the 1,3-distances and the conformations are practically the same in many cases (Chart I).

The primary bromides 6 and 7 provide a suitable starting point for a discussion of  $\rho$  values because they undergo concerted nucleophilic displacement by the solvent in a  $k_s$  process.<sup>8d</sup> Since the charge developed

Chart I  
Reaction Constants  $\rho$  (in brackets)  
Determined in 80 vol % Ethanol

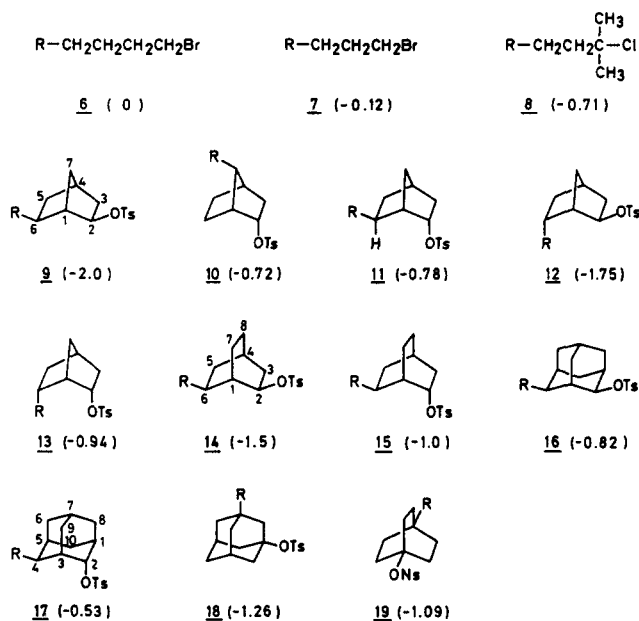

at C-1 in the transition state is negligible, very little electrostatic interaction with the substituent R occurs, which accounts for the observed low  $\rho$  values of zero and  $-0.12$ , respectively. The tertiary chlorides 8, however, ionize with far less nucleophilic assistance by the solvent and therefore react essentially by way of a carbocation,<sup>10</sup> which leads to a much higher  $\rho$  value of  $-0.71$ .<sup>8b</sup>

Before employing  $\rho$  values to gauge inductivity, it should be ascertained that true cationic processes are being observed. This has been demonstrated for the solvolysis of 2-*exo*- and 2-*endo*-norbornyl toluenesulfonates 9 and 10, R = H, respectively, and the corresponding bromides in 90% ethanol and in 2-methoxyethanol, which react in first-order processes even in the presence of strong nucleophiles, such as KOH and  $C_6H_5SNa$ .<sup>6</sup> It should, therefore, also apply to the related secondary structures 14–17, R = H. The solvolysis of the bridgehead sulfonates 18 and 19 are necessarily cationic processes and therefore serve as models for this type of reaction.

### Inductivity and Bridging

Widely different inductivities are observed for the 6-*exo*-substituted-2-*exo*-norbornyl tosylates 9 ( $\rho = -2.0$ )<sup>11</sup> and their 7-*anti*-2-*endo* and 6-*exo*-2-*endo* isomers 10 ( $\rho = -0.72$ )<sup>12</sup> and 11 ( $\rho = -0.78$ ),<sup>11</sup> respectively. These spectacular logarithmic differences can be rationalized by assuming that through-space induction, which accompanies through-bond induction,<sup>13–15</sup> involves 1,3-bridging.<sup>8e,11</sup> The latter is strong in the transition states for the ionization of 9 because the back lobe of the R-C orbital at C-6 overlaps well with the p orbital of the cationic center in the resulting cation as illustrated in 20. This is shown by plastic framework models (Prentice Hall), using trigonal-bipyramidal metal

(10) Bentley, T. W.; Carter, G. E. *J. Am. Chem. Soc.* **1982**, *104*, 5741.

(11) Fischer, W.; Grob, C. A.; Hanreich, R.; von Sprecher, G.; Waldner, A. *Helv. Chim. Acta* **1981**, *64*, 2298.

(12) Unpublished work in this laboratory.

(13) Lewis, G. N. "Valence and the Structure of Atoms and Molecules"; The Chemical Catalog Co.: New York, 1923.

(14) Ingold, C. K. *Chem. Rev.* **1934**, *15*, 225.

(15) Hoffmann, R. *Acc. Chem. Res.* **1971**, *4*, 1.

(8) (a) Fischer, W.; Grob, C. A. *Helv. Chim. Acta* **1978**, *61*, 1588. (b) Grob, C. A.; Waldner, A. *Ibid.* **1979**, *62*, 1736. (c) Grob, C. A.; Rich, R. *Ibid.* **1979**, *62*, 2793. (d) Grob, C. A.; Waldner, A. *Ibid.* **1980**, *63*, 2152. (e) Grob, C. A.; Schaub, B. *Ibid.* **1982**, *65*, 1720.

(9) Grob, C. A.; Schlageter, M. G.; Schaub, B. *Helv. Chim. Acta* **1980**, *63*, 57.

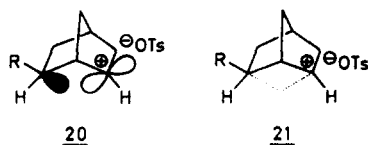

clusters to indicate the orientation of the orbitals at C-2, C-6, and C-7. A simplified picture 21 shows only the respective orbital axes (dotted lines) that converge and intersect. Put in yet another way, 1,3-bridging in the cation from 9 subdivides a six-membered ring into quasi-five- and -three-membered rings, as illustrated in 22.

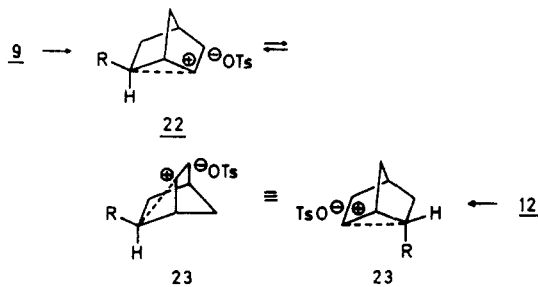

In contrast, the orbital axes at C-7 and C-2 in the ion pair 24 from 10 converge but do not intersect. Overlap

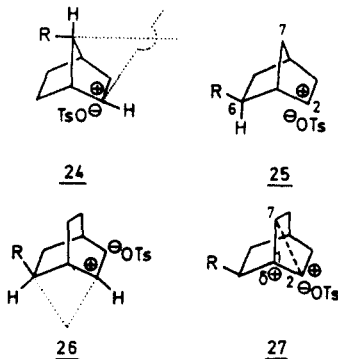

and bridging are therefore reduced. Furthermore, bridging of C-2 by C-7 would subdivide a five-membered ring into highly strained four- and three-membered rings. The observed  $\rho$  value of  $-0.72$  must then be mainly due to through-bond induction. Since bridging affects rates, differential bridging strain should lead to spectacular differences between the rates of stereoisomeric tosylates.

However, bridging strain alone does not account for the low inductivity of  $-0.78$  observed for 6-*exo*-substituted-2-*endo*-norbornyl tosylates 11. In this case, bridging by C-6 in the resulting contact ion-pair 25 is inhibited by the anion that is located on the endo side until it is removed by dissociation in the protic solvent. In contrast, the counterion in the ion-pair 23 from 9 is not in a position to interfere with bridging. Consequently, transmission of the inductive effect in the transition states is not hindered.

The widely different inductivities of the 2-*exo*- and 2-*endo*-tosylates 9 and 11, respectively, are responsible for the large variations of the *exo/endo* rate ratios with the substituents.<sup>11</sup> For  $R = t\text{-C}_4\text{H}_9$ ,  $\text{COOCH}_3$ , and  $\text{Br}$ , the respective  $k_9/k_{11}$  ratios are 2388, 4, and 0.37; i.e., the *exo/endo* rate ratios are reversed when the 6-*exo*-substituent is strongly electron withdrawing. For the unsubstituted tosylates 9 and 11 (or 10), the *exo/endo* rate ratio is 425 at 70 °C, which corresponds to a free energy difference between the two transition states of

5.5 kcal/mol. This frequently debated difference<sup>16</sup> can, therefore, be ascribed to differential bridging in the two transition states. However, inductivity is also sensitive to the orientation of the substituent at C-6 as shown by the  $\rho$  value of  $-1.75$  for the 6-*endo*-substituted 2-*exo*-tosylates 12.<sup>17</sup> Apparently the R to C-6 bond is more polarizable in the W-like configuration 9 than it is in the sicklelike configuration 12.

The *I* effect of substituents at C-6 in the solvolysis of the 2-*exo*-tosylate 9 also has important stereochemical consequences in that 2-*exo*-substitution products only are obtained when R is an electron donor, such as hydrogen or alkyl, whereas 2-*endo*-substitution products are produced when R is an electron-attracting group, such as F,  $\text{COOCH}_3$ , or CN, which strongly reduce bridging.<sup>11,18</sup> This observation supports the hypothesis that induction involves graded bridging.

Substituents at C-6 also affect the ease with which the typical Wagner–Meerwein rearrangements of 2-norbornyl cations take place.<sup>19</sup> Thus, strongly bridged cations 22 should undergo rapid and reversible conversion to epimeric cations 23 because the new bond is already partly formed. In fact, when the substituent R is an electron donor, rearrangement of the cations 22 and 23 is faster than capture by a nucleophilic solvent. In such cases 9 and 12, which are the precursors of the cations 22 and 23, afford the same yields of the same products. However, when R is an electron acceptor, rearrangement is slower than capture by solvent, and different product compositions result. Thus, not only are the relative rates of 2-*exo*- and 2-*endo*-norbornyl derivatives determined by the degree of bridging but also the structure and configuration of the derived products.

This conclusion is at variance with Brown's steric explanation<sup>16</sup> for the high *exo/endo* rate ratio and the exclusive formation of 2-*exo*-substitution products observed in the solvolysis of unsubstituted 2-*exo*- and 2-*endo*-norbornyl sulfonates 9 and 11,  $R = \text{H}$ .<sup>16</sup> According to his hypothesis, rates and products reflect hindered ionization of 2-*endo*-sulfonates by the C-6-*endo*-H atom and hindered *endo* attack of nucleophiles at C-2 of the intermediate unbridged 2-norbornyl cation. But as mentioned above, *exo/endo* rate ratios vary over a range of more than 6000 as the 6-*exo*-substituent changes and both 2-*exo*- and 2-*endo*-substitution products are obtained when bridging is reduced by electron-attracting substituents at C-6. Furthermore, substitution of a methyl or a bulky *tert*-butyl group for a 6-*exo*- or a 6-*endo*-H atom in the tosylates 11 and 13 has only a small effect on the rate.<sup>19</sup> Steric effects are therefore not the key to the problem.

The 6-*exo*-substituted-2-*exo*- and 2-*endo*-bicyclo[2.2.2]octyl tosylates (14 and 15) resemble the respective 2-norbornyl tosylates 9 and 11 in that the conformations and the distances between the substituents and the OTs groups are practically the same. Nevertheless, the inductivity of 14 ( $\rho = -1.50$ ) is smaller than that of 9 ( $\rho = -2.0$ ), whereas the inductivity of 15 ( $\rho = -1.0$ ) is larger

(16) See, for example: (a) Brown, H. C. "The Nonclassical Ion Problem", with comments by Schleyer, P. v. R.; Plenum Press: New York, 1977. (b) Brown, H. C., accompanying paper in this issue.

(17) Grob, C. A.; Günther, B.; Hanreich, R. *Helv. Chim. Acta* 1981, 64, 2312.

(18) Grob, C. A.; Herzfeld, D. *Helv. Chim. Acta* 1982, 65, 2443.

(19) Grob, C. A.; Günther, B.; Hanreich, R. *Helv. Chim. Acta* 1982, 65, 2110.

than that of 11 ( $\rho = -0.78$ ). The smaller  $\rho$  value for the *exo*-tosylates 14 is evidently due to the fact that the orbital axes at C-2 and C-6 of the cation 26 intersect at a smaller angle than in the cation 21 from 9. Hence, overlap or bridging is reduced. On the other hand, bridging of C-2 by C-7 is stronger in the cation 27 from 15 than in the cation 25 from 11. Therefore, more positive charge is transferred from C-2 to C-1 in 27, where it increases the inductive through-bond interaction with the substituent at C-6.

The diequatorial 4-substituted-2-adamantyl tosylates 16 have the same W-like conformation of the R-C-C-C-X sequence as 9 and 14 and also react by a cationic process.<sup>20</sup> If through-bond induction were the only factor, the inductivities of all three series would be similar. In fact,  $\rho$  for 16 is only  $-0.82$  compared to  $-2.0$  for 9 and  $-1.50$  for 14. The reason for the strikingly low  $\rho$  value for 16 could be that effective bridging of C-2 by C-4 would require these atoms to adopt trigonal-bipyramidal conformations in the cation 28 and that this would strongly distort the ideal chair conformations of the cyclohexane rings. Bridging is therefore severely reduced, even when R in 16 is an electron donor, such as H and CH<sub>3</sub>. In agreement with this conclusion, solvolysis of 16 is comparatively slow and occurs with almost equal retention and inversion at C-2. Furthermore, less than 0.5% rearrangement is observed.<sup>20</sup> It is noteworthy that the relative inertness of cyclohexyl halides in S<sub>N</sub>2 reactions has for a long time been attributed to the ring distortion caused by incorporating a pentacoordinate C atom in the transition state.<sup>21</sup>

The  $\rho$  value of  $-0.53$  for the 2(a)-adamantyl tosylate 17 corresponds to the lowest inductivity yet observed for a cationic process. In this case induction is restricted to a through-bond interaction, because overlap of the orbitals involved in bridging of C-2 and C-4 is excluded.

The R-C-C-C-OTs sequence in the 3-substituted-1-adamantyl tosylates 18 has the W-like conformation also present in 9, 14, and 16. However, the substituent and the OTs group are both located at bridgehead positions. The  $\rho$  value of  $-1.26$  indicates a fairly large interaction between C-1 and C-3, although bridging in the derived cation 29 should cause flattening of the bridgehead C atoms and hence generate strain.<sup>8e</sup> However, the orbital axes at C-1 and C-3 intersect inside the cage, i.e., in a region of high electron density, which is apparently conducive to induction. This view is supported by the <sup>1</sup>H NMR spectrum of the 1-adamantyl cation 29, R = H, under stable ion conditions; for all three, bridgehead H atoms are more deshielded, namely, by 0.90 ppm, than the six H atoms adjacent to the cationic center.<sup>22</sup> Selective withdrawal of electron density from the bridgehead atoms amounts to triple 1,3-bridging, as shown in 29.

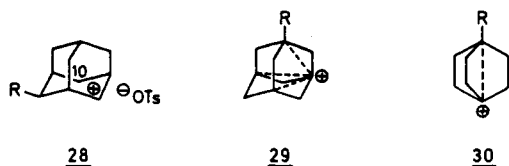

28

29

30

(20) Pritt, J. R.; Whiting, M. C. *J. Chem. Soc., Perkin Trans. 2* 1975, 1458. Bentley, T. W.; Schleyer, P. v. R. *J. Am. Chem. Soc.* 1976, 98, 7658. Lenoir, D.; Schleyer, P. v. R. *J. Chem. Soc. D* 1970, 941.

(21) Brown, H. C.; Fletcher, R. S.; Johannesen, R. B. *J. Am. Chem. Soc.* 1951, 73, 212.

(22) Schleyer, P. v. R.; Fort, R. C.; Watts, W. E.; Comisarow, M. B.; Olah, G. A. *J. Am. Chem. Soc.* 1964, 86, 4195.

Table I  
Relative First-Order Rate Constants in 80 vol %  
Ethanol at 70 °C and Exo/Endo Rate Ratios

compd	$k_{rel}$	$k_{exo}/k_{endo}$
31	4	1125 (at 130 °C)
31	$4 \times 10^{-3}$	
32	3113	425
32	7.3	
33	279	51
33	5.5	
34	247	13
34	18.7	
35	8.4	13
35	0.65	
36	338	1.8
36	189	
37	322	
38	1	

The  $\rho$  value of  $-1.09$  observed for the solvolysis of the 4-substituted-1-bicyclo[2.2.2]octyl *p*-nitrobenzenesulfonates 19<sup>7c,23</sup> is surprisingly large considering that 1,4-bridging in the derived cation produces the strained propellane-like structure 30. On the other hand, the three equivalent through-bond interactions should also contribute to overall inductivity.

### Relative Rates of Epimeric Tosylates

Secondary bonding or bridging, as defined above, was inferred from observed relationships between the structure and inductivity of model compounds, a method that calls for the synthesis and investigation of numerous derivatives. A less tedious way to detect bridging is to determine the rates and products of epimeric *exo* and *endo* bicyclic sulfonates.<sup>24</sup> These *exo/endo* rate ratios frequency differ considerably (Table I) although the same carbocations are involved as intermediates. Provided that both epimers react essentially by cationic processes, their relative rates and products are indicative of the degree of bridging in the respective transition states. Several such cases are listed in Table II, where *exo* and *endo* denote a secondary *exo* or *endo* tosyloxy group at the reaction center. Bridging involves a  $\beta$ -methylene group; the "substituents" are therefore hydrogen atoms, the steric effects of which are small.

The 8-*exo*-bicyclo[3.2.1]octyl tosylate 31 reacts ca.  $10^3$  times faster than the *endo* epimer. Since the orbital axes converge more in the cation 39 from *exo*-31, overlap and, hence, bridging should be stronger than in the cation 40 from *endo*-31. This also follows from

(23)  $\rho$  values for *p*-nitro- and *p*-methylbenzenesulfonates do not differ significantly.

(24) Grob, C. A. *Angew. Chem., Int. Ed. Engl.* 1982, 21, 87. Grob, C. A.; Waldner, A. *Tetrahedron Lett.* 1981, 22, 3235. Grob, C. A., Zutter, U. *Ibid.* 1982, 23, 2849.

a consideration of the bridging strains generated in the quasi-small rings in 41 and 42. It is confirmed by the formation of the *exo*-alcohol 31 with retention from *exo*-31 and with inversion from *endo*-31. Additional products derive from the rearranged bicyclo[3.3.0]octyl-2-yl cation 43 only and not from the far more strained bicyclo[4.2.0]oct-2-yl cation 44. Differential bridging strain in the ionization of epimeric tosylates thus explains relative rates and products.

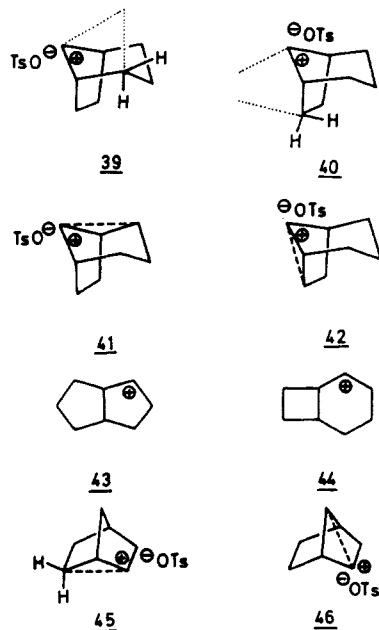

This principle also applies to the 2-*exo*- and 2-*endo*-norbornyl tosylates 32, which show a similar rate ratio of 425 at 70 °C and yield 2-*exo*-alcohols 32 exclusively. This finding confirms that bridging by C-6 as in 45 involves less strain than bridging by C-7, as in 46.

The *exo/endo* rate ratio for the more flexible 2-*exo*- and 2-*endo*-bicyclo[3.3.1]nonyl tosylates 33 of 51 (Table I) is considerably smaller than that for 32. In these compounds 1,3-bridging leads to contraction of an eight- to a quasi-seven-membered ring and of a six- to a quasi-five-membered ring, as in 47 and 48, respectively. As models show, incorporating two pentacoordinated C atoms in one cyclohexane ring, as in 48, entails more strain than incorporating them in different rings, as in 47.

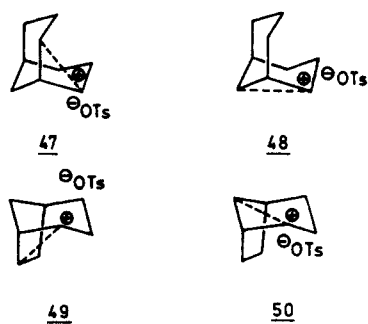

The *exo/endo* rate ratio for the 2-*exo*- and 2-*endo*-bicyclo[3.2.1]octyl tosylates 34 is only 13 (Table I). In these epimers 1,3-bridging would lead to the cations 49 and 50 in which the seven- and six-membered rings are contracted to a quasi-six-membered and a slightly more strained five-membered ring, respectively. Hydrolysis of the *exo*-tosylate 34 yields the *exo*-alcohol 34 with

retention of configuration. The more weakly bridged *endo*-tosylate 34 yields 8% of the inverted *exo*-alcohol beside the *endo*-alcohol 34.

The rate ratio for the 6-*exo*- and 6-*endo*-bicyclo[3.2.1]octyl tosylates 35 is also 13 (Table I). In these epimers 1,3-bridging would lead to the cations 51 and 52 in which the seven- and five-membered rings are contracted to the respective quasi-six- and -4-membered rings. Again, the presumably more strongly bridged cation 51 yielded the *exo*-alcohol 35 with retention, whereas the less bridged cation 52 afforded the inverted *endo*-alcohol 35.

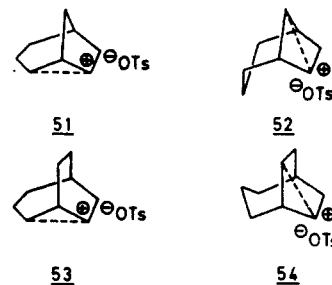

According to molecular models, the bridging strains in the cations 53 and 54 from the 6-*exo*- and 6-*endo*-bicyclo[3.2.2]nonyl tosylates 36 are not appreciably different. The observed very small *exo/endo* rate ratio of 1.8 is therefore not surprising, the larger and more flexible bridge again providing more assistance to ionization. Since only rearranged alcohols and olefins are obtained, stereochemical evidence for bridging is lacking. Finally, the stereoisomers of bicyclo[2.2.2]oct-2-yl tosylate 37 are enantiomers and therefore chemically equivalent.

### Relative Rates of Secondary Bicyclic Tosylates

The relative rates of the unsubstituted secondary tosylates 31–37 in Table I emphasize the importance of bridging strain in determining their reactivity. The 2-adamantyl tosylate 38 was chosen as the standard ( $k_{rel} = 1$ ) because of its resistance to bridging and consequent low rate. On this scale, 2-*exo*-norbornyl tosylate 32 reacts more than  $10^3$  times faster. Larger bridging strain and, hence, lower inductivity account for the ca. tenfold lower rate of 37 as compared to the structurally similar *exo*-32. The *exo*-tosylates 33, 34, and 36 and the *endo*-tosylate 36 as well as 37 react  $10^2$ – $10^3$  times faster than 38. It is, therefore, assumed that their ionization involves less bridging strain than in the case of *exo*-31, *endo*-32, *endo*-33, and *endo*-34, the relative rates of which vary between 4 and 19. Relative rates of *endo*-31 and *endo*-35 are below that for 38, probably because bridging involves contractions of a five-membered ring to a quasi-four-membered ring.

However, further factors must be involved as evidenced by the very small  $k_{rel}$  of  $4 \times 10^{-3}$  for *endo*-31. In the resulting bicyclo[3.2.1]octyl 8-cation 55 from

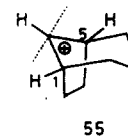

*endo*-31 and *exo*-31, hyperconjugation of the  $\beta$ -CH bonds at C-1 and C-5 is excluded because they are orthogonal to the p orbital at C-8. Furthermore, enlarging

the bond angle at C-8 toward  $120^\circ$  in the five- and 6-membered rings increases strain. However, consideration of all factors concerned confirms the prevailing role of bridging strain.

### Symmetrical and Unsymmetrical Bridging

In his original papers, Winstein<sup>2</sup> suggested the symmetrically bridged "nonclassical" structure **56** for the



56

2-norbornyl cation. The latter was considered to be a resonance hybrid of the contributing forms **56a-c** and

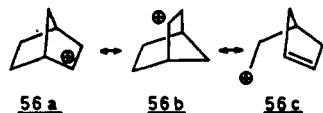

56 a

56 b

56 c

therefore to enjoy extra stabilization. In fact, the transition-state energy for the ionization of *exo*-**32** (Table I) is exceptionally low as evidenced by its high rate relative to the *endo*-epimer **32** and to other secondary bicyclic tosylates (Table I). This can be ascribed to its large inductivity ( $\rho = -2.0$ , Chart I), which reflects unusually strong bridging in the transition state and in the resultant ion-pair **45**. The cation in the latter was therefore formulated as an unsymmetrically bridged species, like its C-6-substituted derivatives **22**, R = alkyl, which are necessarily unsymmetrical due to the absence of a plane of symmetry. It should also be pointed out that the ability of carbocations to undergo symmetrical bridging, as assumed for the 2-norbornyl cation,<sup>2</sup> does not by itself guarantee special stability. This is shown by the behavior of *endo*-**34** and *exo*-**35**, which could ionize directly to the symmetrically bridged cations **57** and **58**, respectively. Yet *endo*-**34** is less



57



58

reactive than the *exo*-epimer **34**, which cannot form **57** directly. Likewise, *exo*-**35** reacts only 13 times faster than *endo*-**35** and is unreactive compared to *exo*-**32** (Table II). Unsymmetrically bridged structures are therefore preferred for the above secondary bicyclic cations.

Nevertheless, the unsubstituted 2-norbornyl cation could be a special case because the large strain already present in norbornane (17 kcal/mol)<sup>25</sup> would tend to reduce the energy difference between a symmetrically and an unsymmetrically bridged structure. In fact, recent theoretical calculations at the most advanced level by Schaefer et al.<sup>4</sup> imply that these structures are essentially of equal energy. On the other hand, recent

NMR spectroscopic studies of the long-lived norbornyl cation, employing highly refined techniques, have led Olah<sup>3</sup> and Saunders<sup>26</sup> to uphold Winstein's symmetrically bridged structure **56**. It should be stressed, however, that these studies were carried out at very low temperatures on static-free cations in nonnucleophilic media, whereas in solvolyses the rates of formation of ion pairs and their subsequent reactions in protic solvents are studied at ambient temperatures. The cationic species involved might therefore differ slightly. In fact, the reversible rearrangement of unsymmetrically bridged norbornyl cations **22** and **23** could become so fast as to be indistinguishable from a skeletal vibration.<sup>11</sup> In view of the above results, the discussion needs no longer to be centered on whether the norbornyl cation is bridged or unbridged but whether bridging is symmetrical or unsymmetrical. In fact, Schleyer and Olah have recently discussed unsymmetrical or partial bridging in other secondary carbocations under stable ion conditions.<sup>27</sup>

But an important distinction between these descriptions remains. According to Winstein,<sup>2</sup> the symmetrically norbornyl cation **56** derives its stabilization from delocalization of the C-1 to C-6  $\sigma$ -bond with concomitant formation of a three-center two-electron bond. According to the hypothesis presented here, all the electrons around C-6, and particularly the C-6-*exo*-H electrons in **45**, participate in the bridging of C-6 to C-2. The total interaction, which depends so strongly on the *I* effect of the substituent R, can be roughly dissected into a through-bond and a through-space component, which, in this context, is referred to as bridging.

### Concluding Remarks

As these results show the solvolytic ionization rates of several alicyclic arenesulfonates are directly related to the inductive constants of neighboring substituents; furthermore, the sensitivity of the rate constants to the *I* effect, i.e., the inductivity of the system, varies strongly with structure, even when through-bond distances and conformations are the same. It also appears that through-space induction dominates when inductivity is high.

The experimental results can be explained if the assumption is made that through-space induction involves graded bridging of the cationic carbon by a neighboring pentacoordinate carbon atom. Being a bonding interaction, bridging is strengthened by electron donors and weakened by electron acceptors on the bridging carbon. Therefore, it controls the rate of formation of carbocations as well as the stereochemical outcome of their reactions. The inductivities of model compounds make it evident that through-space induction and, hence, bridging are directional interactions. They also provide a rationale for the frequently observed differences between the rates and products of epimeric alicyclic sulfonates, notably of norbornyl derivatives.

(26) Saunders, M.; Kates, M. R. *J. Am. Chem. Soc.* 1980, 102, 6867.

(27) Schleyer, P. v. R.; Lenoir, D.; Mison, P.; Liang, G.; Surya Prakash, G. K.; Olah, G. A. *J. Am. Chem. Soc.* 1980, 102, 683.

(25) Engler, E. M.; Androse, J. D.; Schleyer, P. v. R. *J. Am. Chem. Soc.* 1973, 95, 8005.